

**Troubleshooting Chart:**

Problem	Cause	Solution
1. No discharge	a. No water b. Magnetic valve not functioning c. Excessive water pressure  d. Eductor clogged e. Clogged water inlet strainer	a. Open water supply b. Install valve parts kit c. Install regulator if water pressure exceeds 60 PSI (flowing) d. Clean* or replace e. Disconnect inlet water line and clean s strainer
2. No concentrate draw	a. Clogged foot valve b. Metering tip or eductor has scale build-up c. Low water pressure  d. Discharge tube and/or flooding ring not in place  e. Concentrate container empty f. Inlet hose barb not screwed into eductor tightly g. Clogged water inlet strainer h. Air leak in chemical pick-up tube	a. Clean or replace b. Clean (descale)* or replace  c. Minimum 20 PSI (with water running) required to operate unit properly d. Push tube firmly onto eductor discharge hose barb, or replace tube if it doesn't have a flooding ring. e. Replace with full container f. Tighten, but do not overtighten  g. Disconnect inlet water line and clean strainer h. Put clamp on tube or replace tube if brittle
3. Excess concentrate draw	a. Metering tip not in place b. Chemical above eductor	a. Press correct tip firmly into barb on eductor b. Place concentrate below the eductor
4. Failure of unit to turn off	a. Water valve parts dirty or defective b. Magnet doesn't fully return c. Push button stuck	a. Clean* or replace with valve parts kit b. Make sure magnet moves freely. c. Remove button and clean cabinet/button to remove any dirt lodged in slide recess
5. Excess foaming in discharge	a. Air leak in pick-up tube	a. Put clamp on tube or replace tube if brittle

\* In hard water areas, scale may form inside the discharge end of the eductor, as well as in other areas of the unit that are exposed to water. This scale may be removed by soaking the eductor in a descaling solution (deliming solution). To remove an eductor located in the cabinet, firmly grasp water valve and unthread eductor. Replace in same manner. Alternatively, a scaled eductor can be cleaned (or kept from scaling) by drawing the descaling solution through the unit. Operate the unit with the suction tube in the descaling solution. Operate the unit until solution is drawn consistently, then flush the unit by drawing clear water through it for a minute. Replace concentrate container and put suction tube into concentrate.



## MaxiMizer™ II Proportioning System with E-gap Eductors 1,2, 3 & 4 Button units

**Package Contains:**

1. Proportioner unit.
2. Supply tube(s).
3. Foot valve(s) and weight(s).
4. Discharge tube(s).
5. Metering tip kit(s).
6. Mounting anchor kit.
7. Drip tray(s) for 1 GPM eductor(s) only.
8. Hose hook(s) for 3.5 GPM eductors (s) only.
9. Instruction sheet.

### THANK YOU FOR YOUR INTEREST IN OUR PRODUCTS

Hydro Systems manufactures quality chemical proportioning equipment. Please use this equipment carefully and observe all warnings and cautions.

\*\*\*\*\* NOTE \*\*\*\*\*

<b>WEAR</b>	protective clothing and eyewear when dispensing chemicals or other materials.
<b>ALWAYS</b>	observe safety and handling instructions of the chemical manufacturers.
<b>ALWAYS</b>	direct discharge away from you or other persons or into approved containers.
<b>ALWAYS</b>	dispense cleaners and chemicals in accordance with manufacturer's instructions. Exercise <b>CAUTION</b> when maintaining your equipment.
<b>KEEP</b>	equipment clean to maintain proper operation.
<b>WEAR</b>	protective clothing and eyewear when working in the vicinity of all chemicals, filling or emptying equipment or changing metering tips.
<b>ALWAYS</b>	re-assemble equipment according to instruction procedures. Be sure all components are firmly screwed or latched into position.
<b>ATTACH</b>	only to tap water outlets (85 PSI maximum).
<b>NOTE</b>	If the unit is used to fill a sink or the discharge hose can be placed into a sink, the unit must be mounted so that the bottom of the cabinet is above the overflow rim of the sink.

**Installation and Operation:**

(Repeat steps as necessary for each eductor your unit contains.)

1. Unlock the front door panel and open it.
2. To mount the unit to a wall, drill mounting holes and insert the plastic toggle anchors provided into the holes. Use the screws provided to secure the unit to the wall.
3. Select a metering tip (see next section) and insert the tip into the eductor hose barb.
4. Connect a long, flexible discharge tube to the bottom of any 3.5 GPM (yellow) eductor, applying the end opposite the hook. Route the hose out the bottom of the unit, through the holes provided. The hook allows the discharge tube to hang neatly when not in use. Make sure all discharge tubes are fully engaged onto the eductors.
5. Connect water supply hose of at least ½" ID to water inlet swivel at right side of manifold. (Minimum 25 PSI pressure, with water running, is required for proper operation.) Route hose out the side of the cabinet, through the hole provided, and attach the hose to the water supply source. Turn water supply on. If needed, the front panel can be removed by loosening the screws inside the bottom edge and then lifting the front off.
6. Install the suction tube as follows:
  - Slide a ceramic weight over one end of the piece of tubing.
  - Push the hose barb end of a foot valve into one end of the open tube.
  - Slide the weight down to the foot valve.
  - Place foot valve end of suction tube into the concentrate container and put container into proportioner cabinet.
  - Push the other (open) end of the suction tube assembly over the hose barb/metering tip on the eductor.
  - REMEMBER TO CHECK FOOT VALVE STRAINER FOR CLOGGING PERIODICALLY. CLEAN IF NECESSARY.
7. Close front door panel and lock. If dispenser has any 1 GPM eductors, be sure a drip tray is in its place at the bottom of the shelf, below concentrate container, for all 1 GPM stations.
8. Write product name on one of the labels supplied and apply the label under the button to correspond to the product that will be dispensed by depressing that button, and the type of container the solution will be dispensed into.
9. Push button to start flow of desired water/concentrate solution, and hold until solution starts to be discharged. (Be sure to have a bottle or other receptacle under the discharge tube.) Prime each of the supply tubes in this way. Then push the button whenever dispensing is desired, and release button to stop flow of solution. Buttons may be converted to twist-to-latch locking buttons by installing the latch spring provided (see parts diagram for placement). This allows continuous dispensing without holding button.



**Metering Tip Selection:**

The final concentration of the dispensed liquid is related to both the size of the metering tip opening and the viscosity of the liquid being siphoned. If product viscosity is noticeably greater than that of water, consult the procedure for Measurement of Concentration on the next page to achieve your desired water-to-product ratio. For water-thin products, use the chart on the next page as a **guideline**. Because such factors as inlet water pressure and temperature can affect dilution ratios, the figures listed on the chart are only approximate. Test the actual dilution you are achieving using the Measurement of Concentration procedure for best results. Use the undrilled, clear tip for drilling a size not listed.

**Measurement of Concentration:**

You can determine the dispensed water-to-product ratio for any metering tip and product viscosity. All that is required is to operate the primed dispenser for a minute or so and note two things: the amount of dispensed solution, and the amount of concentrate used in preparation of the solution dispensed. The water-to-product ratio is then calculated as follows:

Dilution Ratio (X:1) where X = Amount of Mixed Solution - Amount of Concentrate Drawn  
 Amount of Concentrate Drawn Dilution Ratio, then, equals X parts water to one part concentrate (X:1). If the test does not yield the desired ratio, choose a different tip and repeat the test. Alternative methods to this test are 1) pH (using litmus paper), and 2) titration. Contact your concentrate supplier for further information on these alternative methods and the materials required to perform them.

APPROXIMATE DILUTIONS AT 40 PSI FOR WATER-THIN PRODUCTS (1.0 CP)				
Tip Color	Orifice Size	Std. Drill Number	Ratio (per Eductor Flow)	
			1 GPM	3.5 GPM
No Tip	.187	(3/16)	3:1	3.5:1
Grey	.128	(30)	3:1	4:1
Black	.098	(40)	3:1	4:1
Beige	.070	(50)	4:1	8:1
Red	.052	(55)	5:1	14:1
White	.043	(57)	7:1	20:1
Blue	.040	(60)	8:1	24:1
Tan	.035	(65)	10:1	30:1
Green	.028	(70)	16:1	45:1
Orange	.025	(72)	20:1	56:1
Brown	.023	(74)	24:1	64:1
Yellow	.020	(76)	32:1	90:1
Aqua	.018	(77)	38:1	128:1
Purple	.014	(79)	64:1	180:1
Pink	.010	(87)	128:1	350:1

**MaxiMizer™ II Parts Diagrams & List**

4-button manifold shown

(3-button similar; see 1-button manifold for fittings on left side of 2-button manifold)

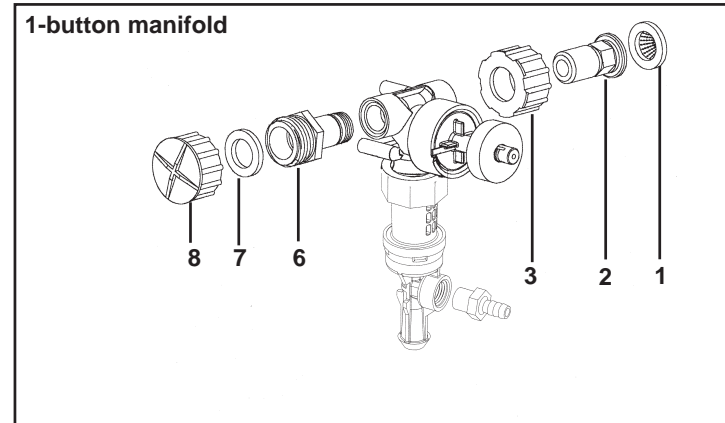
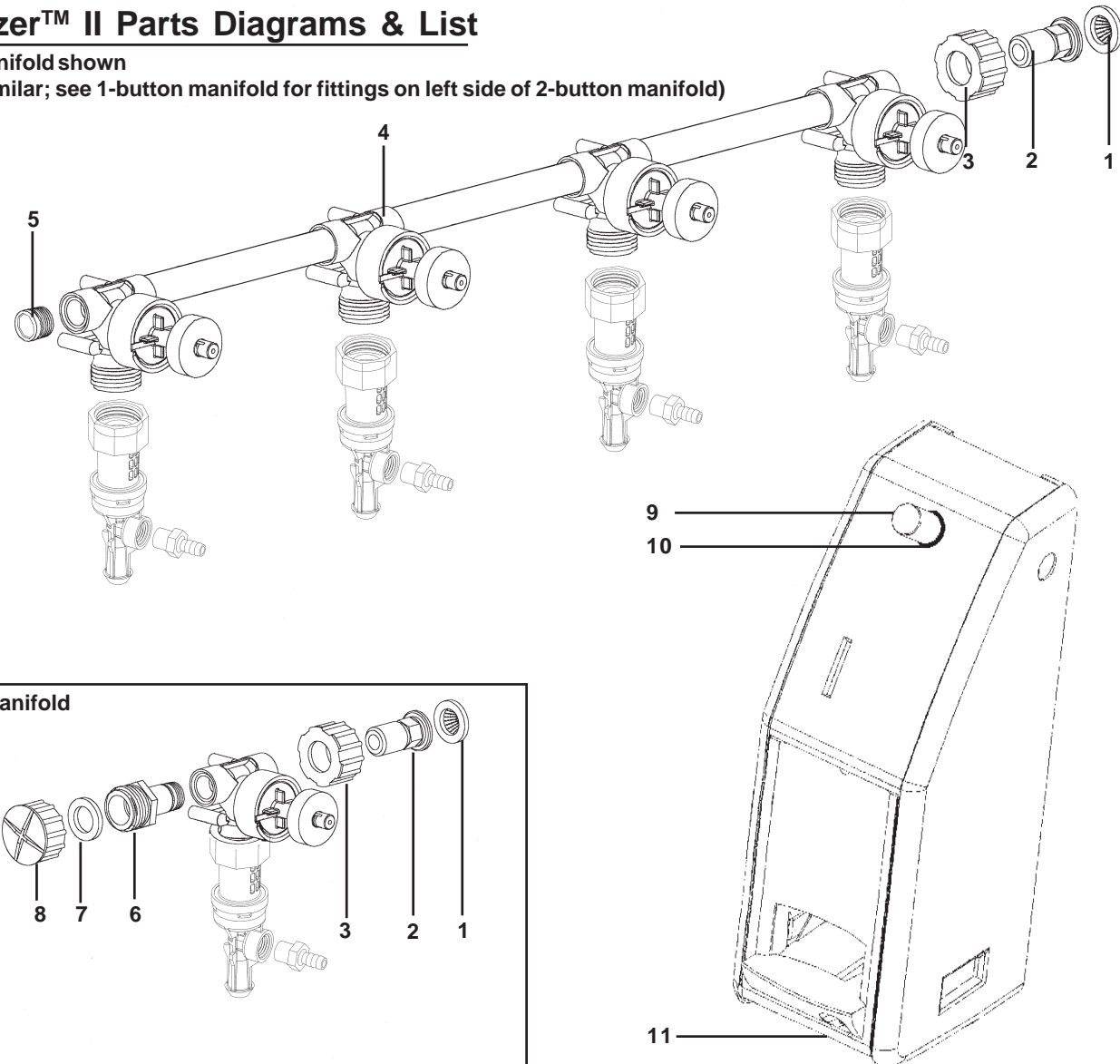

**MaxiMizer™ II Parts Diagrams/List**

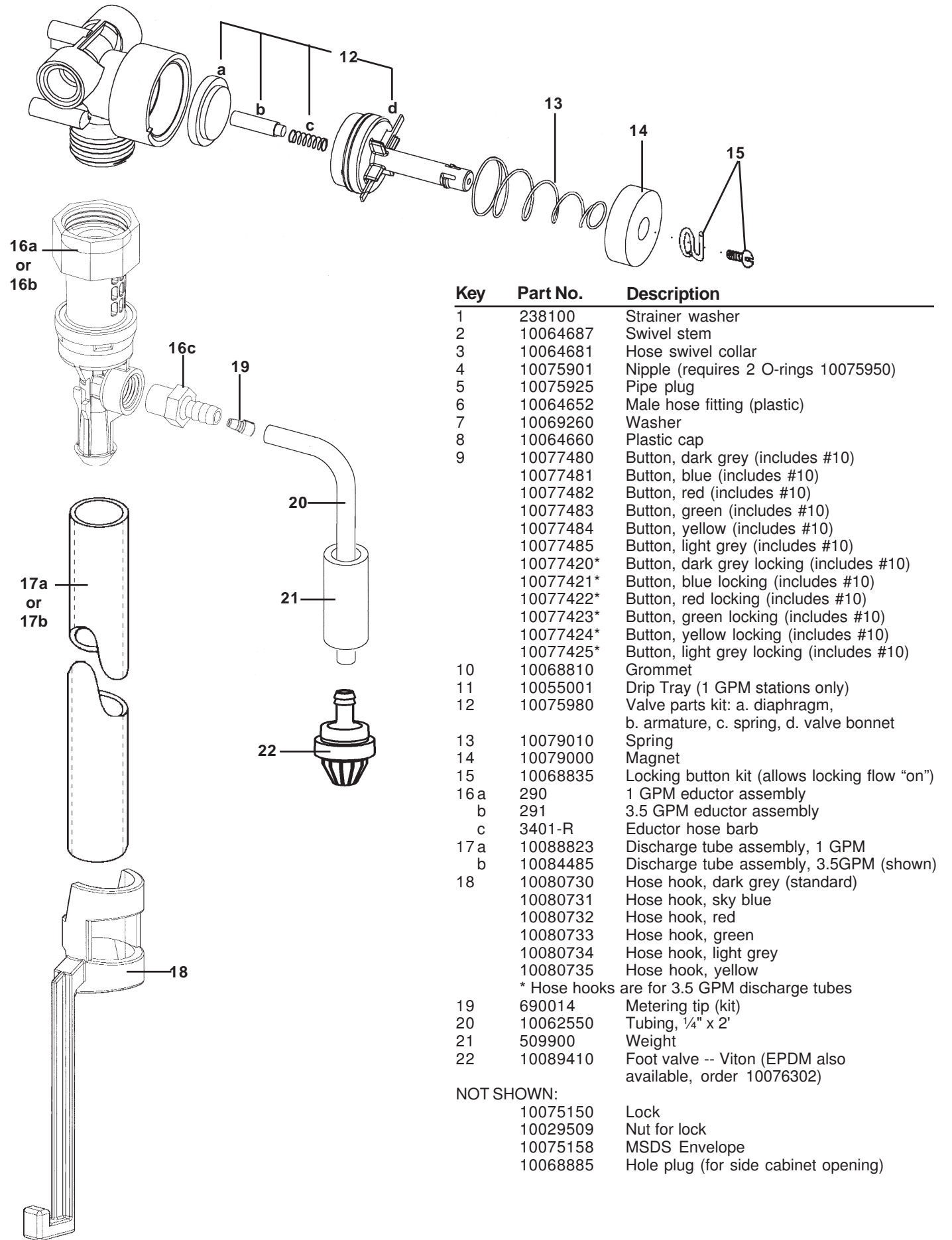

Key	Part No.	Description
1	238100	Strainer washer
2	10064687	Swivel stem
3	10064681	Hose swivel collar
4	10075901	Nipple (requires 2 O-rings 10075950)
5	10075925	Pipe plug
6	10064652	Male hose fitting (plastic)
7	10069260	Washer
8	10064660	Plastic cap
9	10077480	Button, dark grey (includes #10)
	10077481	Button, blue (includes #10)
	10077482	Button, red (includes #10)
	10077483	Button, green (includes #10)
	10077484	Button, yellow (includes #10)
	10077485	Button, light grey (includes #10)
	10077420*	Button, dark grey locking (includes #10)
	10077421*	Button, blue locking (includes #10)
	10077422*	Button, red locking (includes #10)
	10077423*	Button, green locking (includes #10)
	10077424*	Button, yellow locking (includes #10)
	10077425*	Button, light grey locking (includes #10)
10	10068810	Grommet
11	10055001	Drip Tray (1 GPM stations only)
12	10075980	Valve parts kit: a. diaphragm, b. armature, c. spring, d. valve bonnet
13	10079010	Spring
14	10079000	Magnet
15	10068835	Locking button kit (allows locking flow "on")
16 a	290	1 GPM eductor assembly
b	291	3.5 GPM eductor assembly
c	3401-R	Eductor hose barb
17 a	10088823	Discharge tube assembly, 1 GPM
b	10084485	Discharge tube assembly, 3.5GPM (shown)
18	10080730	Hose hook, dark grey (standard)
	10080731	Hose hook, sky blue
	10080732	Hose hook, red
	10080733	Hose hook, green
	10080734	Hose hook, light grey
	10080735	Hose hook, yellow
	* Hose hooks are for 3.5 GPM discharge tubes	
19	690014	Metering tip (kit)
20	10062550	Tubing, 1/4" x 2'
21	509900	Weight
22	10089410	Foot valve -- Viton (EPDM also available, order 10076302)

NOT SHOWN:  
 10075150 Lock  
 10029509 Nut for lock  
 10075158 MSDS Envelope  
 10068885 Hole plug (for side cabinet opening)