

TROUBLESHOOTING CHART:

Problem	Cause	Solution
1. No discharge	a. No water b. Magnetic valve not functioning c. Excessive water pressure d. Eductor clogged	a. Open water supply b. Install valve parts kit c. Install regulator if water pressure exceeds 85 PSI d. Clean* or replace
2. No concentrate draw	a. Clogged foot stainer b. Metering tip or eductor has scale build-up c. Low water pressure d. Discharge tube and/or flooding ring not in place e. Concentrate container empty f. Check valve not screwed into eductor tightly g. Clogged water inlet strainer h. Air leak between tee and pick-up tubing	a. Clean or replace b. Clean (descale)* or replace c. Minimum 25 PSI (with water running) required to operate unit properly d. Push tube firmly onto eductor discharge hose barb, or replace tube if it doesn't have a flooding ring e. Replace with full container f. Tighten, but do not overtighten g. Disconnect inlet water line and clean strainer h. Be sure tubing is secured on tee barbs: try clamps on tee barbs, or replace tee
3. Excess concentrate draw	a. Metering tip not in place	a. Press correct tip firmly into barb on eductor
4. Failure of unit to turn off	a. Water valve parts dirty or defective b. Magnet doesn't fully return c. Push button stuck d. Excessive water pressure	a. Clean* or replace with valve parts kit b. Make sure magnet moves freely. Replace spring if short or weak c. Realign cabinet or clean grommet that button passes through d. Install regulator if pressure exceeds 85 PSI
5. Supply water in concentrate or unit won't hold prime	a. Check valve inoperable	a. Replace check valve

* In hard water areas, scale may form inside the discharge end of the eductor, as well as in other areas of the unit that are exposed to water. This scale may be removed by soaking the eductor in a descaling solution (deliming solution). To remove an eductor located in the cabinet, firmly grasp vacuum breaker and unthread eductor. Replace in same manner. This will avoid loosening the vacuum breaker. Alternatively, a scaled eductor can be cleaned (or kept from scaling) by drawing the descaling solution through the unit. Operate the unit with the suction tube in the descaling solution. Operate the unit until solution is drawn consistently, then flush the unit by drawing clear water through it for a minute. Replace concentrate container and put suction tube into concentrate.



A DOVER RESOURCES COMPANY

Hydro Systems 3798 Round Bottom Road, Cincinnati, OH 45244 s Phone: (513) 271-8800 s Fax: (513) 271-0160

10089655
8/00



MaxiMizer™ II Model 28481

Package Contains:

1. Proportioner unit.
2. Supply tubes (3 pieces).
3. Strainer and weight.
4. Discharge tubes (1 long, 1 short).
5. Metering tip kit.
6. Mounting anchor kit.
7. Drip tray (1).
8. Instruction sheet.

THANK YOU FOR YOUR INTEREST IN OUR PRODUCTS

Hydro Systems manufactures quality chemical proportioning equipment. Please use this equipment carefully and observe all warnings and cautions.

***** NOTE *****

WEAR	protective clothing and eyewear when dispensing chemicals or other materials.
ALWAYS	observe safety and handling instructions of the chemical manufacturers.
ALWAYS	direct discharge away from you or other persons or into approved containers.
ALWAYS	dispense cleaners and chemicals in accordance with manufacturer's instructions. Exercise CAUTION when maintaining your equipment.
KEEP	equipment clean to maintain proper operation.
WEAR	protective clothing and eyewear when working in the vicinity of all chemicals, filling or emptying equipment or changing metering tips.
ALWAYS	re-assemble equipment according to instruction procedures. Be sure all components are firmly screwed or latched into position.
ATTACH	only to tap water outlets (85 PSI maximum).
NOTE	If the unit is used to fill a sink or the discharge hose can be placed into a sink, the unit must be mounted so that the bottom of the cabinet is above the overflow rim of the sink.

Installation and Operation:

If needed, the front panel can be removed by loosening the two screws inside the bottom edge and then lifting the front off.

1. Unlock the front door panel and open it.
2. To mount the unit to a wall, drill mounting holes and insert the plastic toggle anchors provided into the holes. Use the screws provided to secure the unit to the wall.
3. Connect the long, flexible discharge tube to the bottom of the 4 GPM (yellow) eductor. Route the tube out the bottom of the unit, through the hole provided. Make sure all discharge tubes are fully engaged onto the eductors. The hose hook provided may be installed on the end of the longer discharge tube, allowing the tube to be hung up after each use. Gently twist the hook while pushing it over the tubing to install it.
4. Connect water supply hose of at least ½" ID to water inlet swivel at left side of manifold, through the hole in the cabinet. (Minimum 25 PSI pressure, with water running, is required for proper operation.) Attach hose to water supply source. Turn water supply on.
5. Select a metering tip for each eductor (see next section) and insert the tips into the check valve hose barbs.
6. Install the suction tube as follows:
 - Slide a ceramic weight over one end of the 24" piece of tubing.
 - Install the clear plastic strainer in the end of the 24" piece of tubing, and slide the weight down to the strainer.
 - Slide the opposite end of the 24" piece of tubing over the stem of the hose barb tee (the barb which doesn't have another barb opposite it).
 - With strainer hanging down, connect the the 6" piece of tubing to the left hand side on the hose barb tee. Connect the other end of this piece of tubing to the check valve on the left side (grey) eductor.
 - Connect 10" piece of tubing to the right hand side of the hose barb tee. Connect the other end of this piece of tubing to the check valve on the right side (yellow) eductor.
 - Place strainer into the concentrate container and put container in MaxiMizer. REMEMBER TO CHECK STRAINER PERIODICALLY FOR CLOGGING. CLEAN AS NECESSARY.
7. If top front panel was removed to ease installation, reinstall it now. Close front door panel and lock. Be sure a drip tray is in its place at the bottom of the shelf, below concentrate container.
8. Write product name on the label on the front of the cabinet door.
9. Push button to start flow of desired water/concentrate solution, and hold until solution starts to be discharged. (Be sure to have a bottle or other receptacle under the discharge tube.) Prime each of the supply tubes in this way. Then push the button whenever dispensing is desired, and release button to stop flow of solution. Buttons may be converted to twist-to-latch locking buttons by installing the latch spring provided (see parts diagram for placement). This allows continuous dispensing without holding button.

Metering Tip Selection:

The final concentration of the dispensed liquid is related to both the size of the metering tip opening and the viscosity of the liquid being siphoned. If product viscosity is noticeably greater than that of water, consult the procedure for Measurement of Concentration on the next page to achieve your desired water-to-product ratio. For water-thin products, use the chart on the next page as a **guideline**. Because such factors as inlet water pressure and temperature can affect dilution ratios, the figures listed on the chart are only approximate. Test the actual dilution you are achieving using the Measurement of Concentration procedure for best results. Use the undrilled, clear tip for drilling a size not listed.

Metering Tip Selection:

The final concentration of the dispensed liquid is related to both the size of the metering tip opening and the viscosity of the liquid being siphoned. If product viscosity is noticeably greater than that of water, consult the procedure for Measurement of Concentration to achieve your desired water-to-product ratio. For water-thin products, use the chart at right as a **guideline**. Such factors as inlet water pressure and temperature can affect dilution ratios, so the figures listed on the chart are only approximate. Test the dilution you are achieving using the Measurement of Concentration procedure for best results. Use the undrilled, clear tip for drilling a size not listed.

Measurement of Concentration:

You can determine the dispensed water-to-product ratio for any metering tip and product viscosity. All that is required is to operate the primed dispenser for a minute or so and note two things: the amount of dispensed solution, and the amount of concentrate used in preparation of the solution dispensed. The water-to-product ratio is then calculated as follows: Dilution Ratio (X:1) where

$$X = \frac{\text{Amount of Mixed Solution} - \text{Amount of Concentrate Drawn}}{\text{Amount of Concentrate Drawn}}$$

Dilution Ratio, then, equals X parts water to one part concentrate (X:1). If the test does not yield the desired ratio, choose a different tip and repeat the test. Alternative methods to this test are 1) pH (using litmus paper), and 2) titration. Contact your concentrate supplier for further information on these alternative methods and the materials required to perform them.

APPROXIMATE DILUTIONS AT 40 PSI FOR WATER-THIN PRODUCTS (1.0 CP)				
Tip Color	Orifice Size	Std. Drill Number	Ratio (per Eductor Flow)	
			1 GPM	3.5 GPM
No Tip	.187	(3/16)	3:1	3.5:1
Grey	.128	(30)	3:1	4:1
Black	.098	(40)	3:1	4:1
Beige	.070	(50)	4:1	8:1
Red	.052	(55)	5:1	14:1
White	.043	(57)	7:1	20:1
Blue	.040	(60)	8:1	24:1
Tan	.035	(65)	10:1	30:1
Green	.028	(70)	16:1	45:1
Orange	.025	(72)	20:1	56:1
Brown	.023	(74)	24:1	64:1
Yellow	.020	(76)	32:1	90:1
Aqua	.018	(77)	38:1	128:1
Purple	.014	(79)	64:1	180:1
Pink	.010	(87)	128:1	350:1

MaxiMizer II Parts Diagrams/List

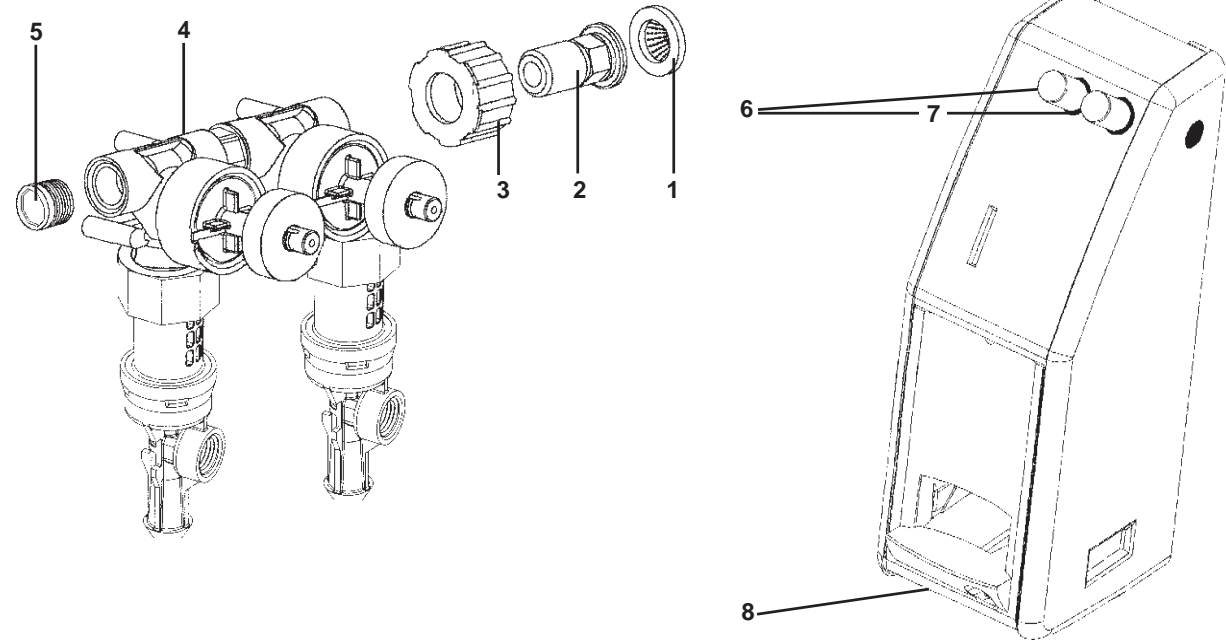

Key	Part No.	Description	Key	Part No.	Description
1	238100	Strainer washer		10082750*	Button, dark grey locking
2	10064687	Swivel stem (3/8" NPT)		10082751*	Button, blue locking
3	10064681	Swivel nut		10082752*	Button, red locking
4	10075912	Nipple (between valves)		10082753*	Button, green locking
	10075950	O-ring (2 required)		10082754*	Button, yellow locking
5	10075925	Pipe plug		10082755*	Button, light grey locking
6	10077480	Button, dark grey (includes #7)			* Locking button parts kits include #7 grommet and #12 spring/screw
	10077481	Button, blue (includes #7)	7	10068810	Grommet
	10077482	Button, red (includes #7)	8	10075160	Drip Tray
	10077483	Button, green (includes #7)			
	10077484	Button, yellow (includes #7)			
	10077485	Button, light grey (includes #7)			

MaxiMizer II Parts Diagrams/List

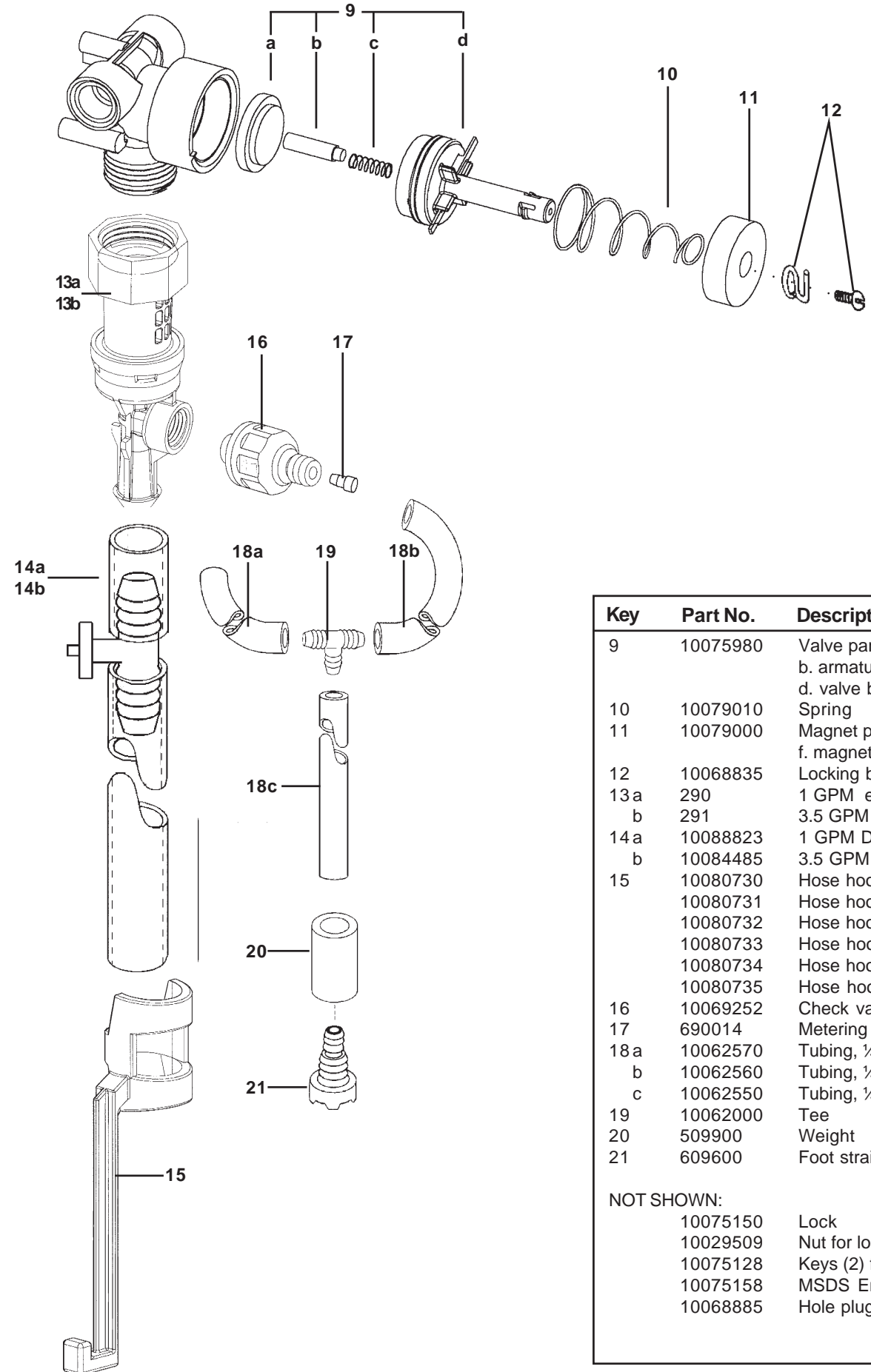

Key	Part No.	Description
9	10075980	Valve parts kit: a. diaphragm, b. armature, c. spring, d. valve bonnet
10	10079010	Spring
11	10079000	Magnet parts kit: e. spring, f. magnet, g. washer, h. screw
12	10068835	Locking button kit
13a	290	1 GPM eductor assembly
b	291	3.5 GPM eductor assembly
14a	10088823	1 GPM Discharge assembly
b	10084485	3.5 GPM Discharge assembly
15	10080730	Hose hook, dark grey (standard)
	10080731	Hose hook, sky blue
	10080732	Hose hook, red
	10080733	Hose hook, green
	10080734	Hose hook, light grey
	10080735	Hose hook, yellow
16	10069252	Check valve
17	690014	Metering tip (kit)
18a	10062570	Tubing, 1/4" x 6"
b	10062560	Tubing, 1/4" x 10"
c	10062550	Tubing, 1/4" x 24"
19	10062000	Tee
20	509900	Weight
21	609600	Foot strainer
NOT SHOWN:		
	10075150	Lock
	10029509	Nut for lock
	10075128	Keys (2) for lock
	10075158	MSDS Envelope
	10068885	Hole plug (for side of cabinet)