

TROUBLESHOOTING CHART:

Problem	Cause	Solution
1. No discharge	a. No water b. Magnetic valve not functioning c. Excessive water pressure d. Eductor clogged	a. Open water supply b. Install valve parts kit c. Install regulator if flowing water pressure exceeds 60 PSI d. Clean* or replace
2. No concentrate draw	a. Clogged foot valve b. Metering tip or eductor has scale build-up c. Low water pressure d. Discharge tube and/or flooding ring not in place e. Concentrate container empty f. Inlet hose barb not screwed into eductor tightly g. Clogged water inlet strainer h. Selector out of position	a. Clean or replace b. Clean (descale)* or replace c. Minimum 25 PSI (with water running) required to operate unit properly d. Push tube firmly onto eductor discharge hose barb, or replace tube if it doesn't have a flooding ring e. Replace with full container f. Tighten, but do not overtighten g. Disconnect inlet water line and clean strainer h. Assure selector is in position desired
3. Excess concentrate draw	a. Metering tip not in place	a. Press correct tip firmly into barb on eductor
4. Failure of unit to turn off	a. Water valve parts dirty or defective b. Magnet doesn't fully return c. Push button stuck d. Excessive water pressure	a. Clean* or replace with valve parts kit b. Make sure magnet moves freely. Replace spring if short or weak c. Realign cabinet or clean grommet that button passes through d. Install regulator if pressure (with water flowing) exceeds 60 PSI
5. Excess foaming in discharge	a. Air leak in pick-up tube b. Inner discharge tube not in place	a. Put clamp on tube or replace tube if brittle b. Install inner discharge tube
6. Water discharge from air vents of eductor	a. Restricted discharge hose b. High water pressure	a. Be sure discharge hose is not immersed, kinked or elevated. Be sure there is no liquid in the discharge hose when beginning to operate dispenser b. Install pressure regulator if flowing water pressure exceeds 60 PSI

* In hard water areas, scale may form inside the discharge end of the eductor, as well as in other areas of the unit that are exposed to water. This scale may be removed by soaking the eductor in a descaling solution (deliming solution). To remove an eductor located in the cabinet, firmly grasp valve and unthread eductor. Replace in same manner. Alternatively, a scaled eductor can be cleaned (or kept from scaling) by drawing the descaling solution through the unit. Operate the unit with the suction tube in the descaling solution. Operate the unit until solution is drawn consistently, then flush the unit by drawing clear water through it for a minute. Replace concentrate container and put suction tube into concentrate.



MaxiMizer™ II Proportioning System Model 2876AG-2

Package Contains:

1. Proportioner unit.
2. Supply tubes, y fitting to assemble tubes.
3. Foot valves and weights.
4. Discharge tubes.
5. Metering tip kits.
6. Mounting anchor kit.
7. Drip tray for 1 GPM eductor.
8. Instruction sheet.

THANK YOU FOR YOUR INTEREST IN OUR PRODUCTS

Please use this equipment carefully and observe all warnings and cautions.

***** NOTE *****

WEAR	protective clothing and eyewear when dispensing chemicals or other materials.
ALWAYS	observe safety and handling instructions of the chemical manufacturers.
ALWAYS	direct discharge away from you or other persons or into approved containers.
ALWAYS	dispense cleaners and chemicals in accordance with manufacturer's instructions. Exercise CAUTION when maintaining your equipment.
KEEP	equipment clean to maintain proper operation.
WEAR	protective clothing and eyewear when working in the vicinity of all chemicals, filling or emptying equipment or changing metering tips.
ALWAYS	re-assemble equipment according to instruction procedures. Be sure all components are firmly screwed or latched into position.
ATTACH	only to tap water outlets (85 PSI maximum).

- Notes:**
- Be sure the products to be dispensed are compatible with the Viton seal on the inlet stub.
 - Each concentrate can be dispensed at its own individual concentration.
 - A small residue of a dispensed chemical will mix with the incoming flow of the next selected chemical in the selector valve, so the products use in this portion of the equipment must be compatible.

Installation and Operation: (if unfamiliar with system components, see parts diagrams and lists before beginning.)

1. Unlock front door panel and open it. If desired, top panel can be removed by loosening the screws with wrench provided.
2. To mount unit to a wall, drill mounting holes and insert plastic toggle anchors provided into holes. Use screws provided to secure unit to the wall.
3. Connect water supply hose of at least ½" ID to water inlet swivel at right side of manifold. (Minimum 25 PSI pressure, with water running, is required for proper operation.) Route hose out side of cabinet, through hole provided, and attach hose to water supply source. Turn water supply on.
4. Select metering tips (up to 4) for selector valve (see next two sections). Push each tip firmly into a separate hose barb extending from selector valve. (It is suggested that "low flow" tip for product to be dispensed at both low flow and high flow be installed in lower right barb.) A tip with no hole (clear plastic color) can be used to block any valve port not being used. (This may be used for dispensing water only.) Select and install a metering tip for single product eductor (right side) in same manner.
5. Connect long, flexible discharge tube to bottom of 3.5 GPM (yellow) eductor. Route hose out bottom of the unit, through hole provided. Hook provided may be installed on long tube. Twist while guiding hook onto end of tube opposite eductor. Hook allows tube to hand from cabinet when not in use. Make sure all discharge tubes are fully engaged onto eductors.
6. One product will be connected to both the 3.5 GPM (yellow) eductor and to one barb on selector valve (to be dispensed at 1 GPM). Rig suction tube assembly for this product as follows:
 - Put the ¼" x 2½" tube on selector valve barb to which you wish to connect product.
 - Locate in-line check valve in installation kit. Note that in-line check valve has arrows molded in side. Install end of in-line check valve to which arrows point into short tube just installed.
 - Install one ¼" x 6" tube on other end of in-line check valve. Put other ¼" x 6" tube on check valve attached to yellow eductor.
 - Install "Y" fitting between two 6" pieces of tubing to connect them.
 - Cut a piece of tubing to reach from "Y" fitting to bottom of concentrate container when it is in place in cabinet. Install this piece of tubing on bottom leg of "Y" fitting, then slide a weight over open end of tube. Put foot strainer into open end of tube.
7. Determine lengths of tubes required to reach from remaining hose barbs on the selector valve to bottoms of various concentrate containers. Cut tubing supplied as needed. Install each of these suction tubes as follows:
 - Slide a ceramic weight over one end of the piece of tubing.
 - Push the hose barb end of a foot valve into one end of the open tube.
 - Slide the weight down to the foot valve.
 - Place foot valve end of suction tube into the concentrate container and place container into MaxiMizer cabinet.
 - Push the other (open) end of the suction tube assembly over the hose barb/metering tip on the eductor.
 - REMEMBER TO CHECK FOOT VALVE STRAINER FOR CLOGGING PERIODICALLY. CLEAN AS NECESSARY.
8. Close front door panel and lock. Put drip tray in place below concentrate container for 1 GPM (selector valve) station.
9. Write product names on labels that have been pre-applied to system cabinet so that they correspond to product that will be dispensed given selector position.
10. Purge air from the system by depressing buttons briefly. There may be some water discharge from eductor vents until air is purged.

Continued ...



A DOVER COMPANY

Hydro Systems 3798 Round Bottom Road, Cincinnati, OH 45244 s Phone: (513) 271-8800 s Fax: (513) 271-0160

10083504 Rev. C
4/05

- Turn knob to select desired product. Push button to start flow of desired water/concentrate solution, and hold until supply tube is primed (filled). (Be sure to have a bottle or other receptacle under the discharge tube.) Prime each tube in the same fashion. Push the appropriate button whenever dispensing is desired. Release button to stop flow of solution. The button for the 3.5 GPM eductor may be converted to a twist-to-latch locking button by installing the latch spring provided (see parts diagram for placement). This allows continuous dispensing without holding button.
- It is essential that the discharge hose not be obstructed. If discharge is restricted, water will flow out the eductor vents. Do not start to operate the dispenser with liquid in the discharge tube.**

Metering Tip Selection:

The final concentration of the dispensed liquid is related to both the size of the metering tip opening and the viscosity of the liquid being siphoned. If product viscosity is noticeably greater than that of water, consult the procedure for Measurement of Concentration below to achieve your desired water-to-product ratio. For water-thin products, use the chart at right as a **guideline**. Because such factors as inlet water pressure and temperature can affect dilution ratios, the figures listed on the chart are only approximate. Test the actual dilution you are achieving using the Measurement of Concentration procedure for best results. Use the undrilled, clear tip for drilling a size not listed, or as a plug for a port not used.

Measurement of Concentration:

You can determine the dispensed water-to-product ratio for any metering tip size and product viscosity. All that is required is to operate the primed dispenser for a minute or so and note two things: the amount of dispensed solution, and the amount of concentrate used in preparation of the solution dispensed. Dilution Ratio, then, equals X parts water to one part concentrate (X:1). If the test does not yield the desired ratio, choose a different tip and repeat the test. Alternative methods to this test are 1) pH (using litmus paper), and 2) titration. Contact your concentrate supplier for further information on these alternative methods and the materials required to perform them.

APPROXIMATE DILUTIONS AT 40 PSI FOR WATER-THIN PRODUCTS (1.0 CP)				
Tip Color	Orifice Size	Std. Drill Number	Ratio (per Eductor Flow)	
			1 GPM	3.5 GPM
No Tip	.187	(3/16)	3:1	3.5:1
Grey	.128	(30)	3:1	4:1
Black	.098	(40)	3:1	4:1
Beige	.070	(50)	4:1	8:1
Red	.052	(55)	5:1	14:1
White	.043	(57)	7:1	20:1
Blue	.040	(60)	8:1	24:1
Tan	.035	(65)	10:1	30:1
Green	.028	(70)	16:1	45:1
Orange	.025	(72)	20:1	56:1
Brown	.023	(74)	24:1	64:1
Yellow	.020	(76)	32:1	90:1
Aqua	.018	(77)	38:1	128:1
Purple	.014	(79)	64:1	180:1
Pink	.010	(87)	128:1	350:1

$$\text{Dilution Ratio (X:1) where X} = \frac{\text{Amount of Mixed Solution} - \text{Amount of Concentrate Drawn}}{\text{Amount of Concentrate Drawn}}$$

MaxiMizer™ II Parts Diagram/List:

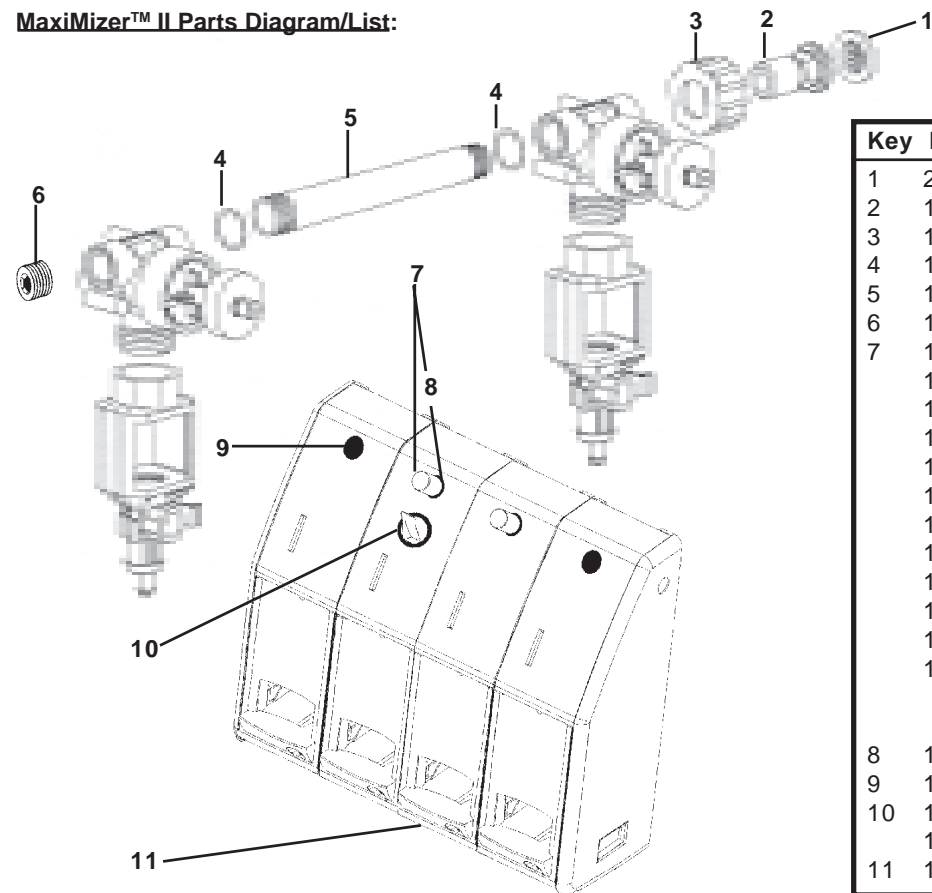

Key	Part No.	Description
1	238100	Strainer washer
2	10064687	Swivel stem
3	10064681	Swivel collar
4	10075950	O-ring
5	10075901	Nipple
6	10075925	Pipe plug
7	10077480	Button, dark grey (includes #8)
	10077481	Button, blue (includes #8)
	10077482	Button, red (includes #8)
	10077483	Button, green (includes #8)
	10077484	Button, yellow (includes #8)
	10077485	Button, light grey (includes #8)
	10082750*	Button, dark grey locking
	10082751*	Button, blue locking
	10082752*	Button, red locking
	10082753*	Button, green locking
	10082754*	Button, yellow locking
	10082755*	Button, light grey locking
	* Locking button kits include #8 grommet and #15 kit	
8	10068810	Grommet
9	10068885	Plug (cabinet openings)
10	10020700	Grommet (selector knob)
	10020900	Retainer ring for grommet #10
11	10075160	Drip tray

MaxiMizer™ II Parts Diagrams/List

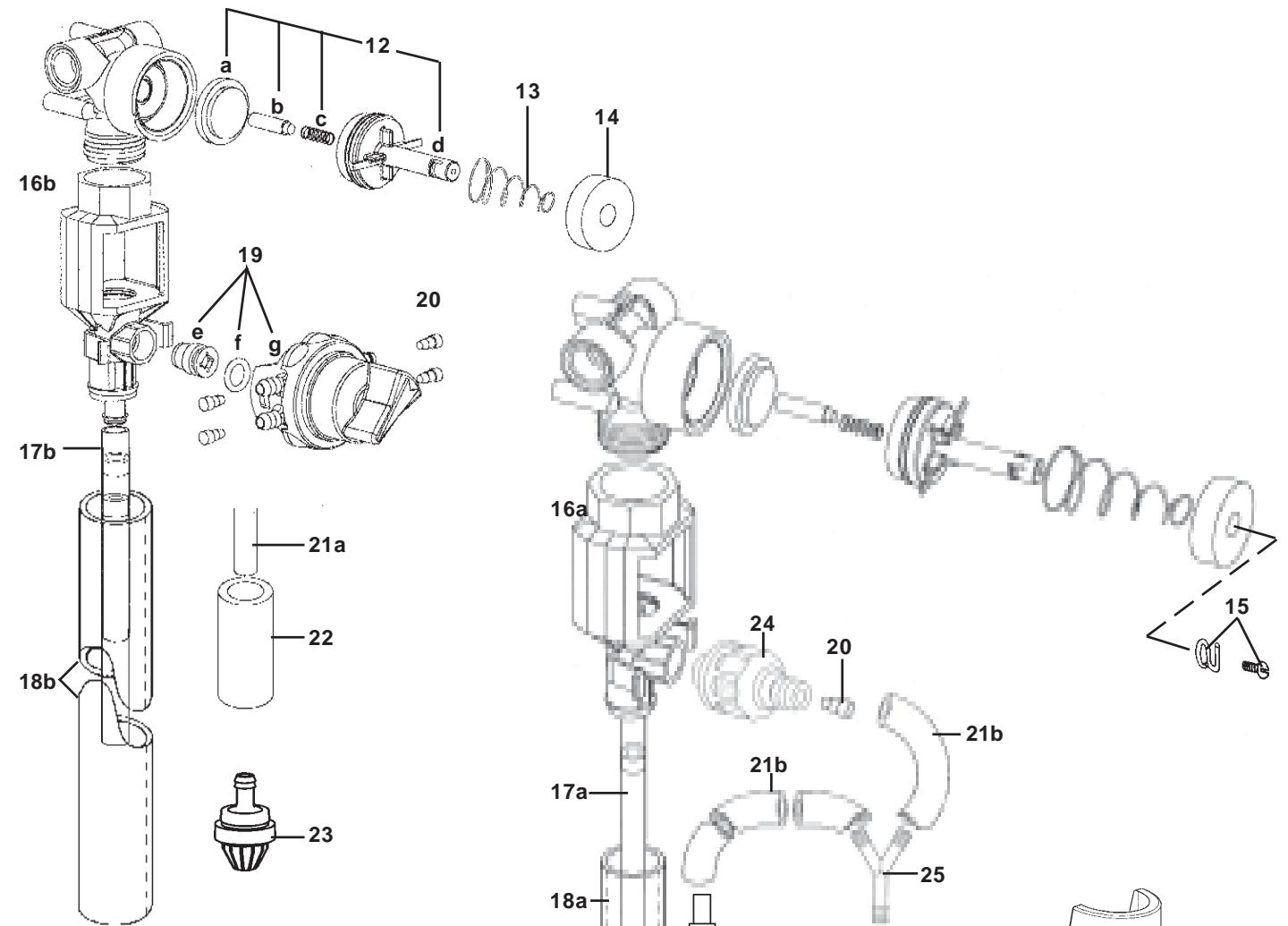

Key	Part No.	Description
12	10075980	Water valve parts kit: a. diaphragm, b. armature, c. spring, d. bonnet
13	10079010	Spring
14	10079000	Magnet
15	10068835	Locking button kit (spring & screw)
16a	176	3.5 GPM Eductor (yellow) kit
b	177	1 GPM Eductor (grey) kit
17a	10070470	Inner discharge tube (for 3.5 GPM)
b	10075155	Inner discharge tube (for 1 GPM)
18a	10077320	Discharge tube (for 3.5 GPM)
b	10075161	Discharge tube (for 1 GPM)
19	10059921	Selector valve replacement kit: e. stub, f. O-ring, g. selector valve
20	690014	Metering tip (kit)
21a	500814	Tubing: 1/4" x 14' (cut as required)
b	10062570	Tubing: 1/4" x 6"
c	10068730	Tubing: 1/4" x 2 1/2"
22	509900	Weight
23	10089410	Foot valve - Viton (EPDM also available: #10076302)
24	10069252	Check valve
25	10068721	"Y" fitting
26	10076303	In-line check valve
27	609600	Strainer
28	10080720	Hose hook, dark grey (standard)
	10080721	Hose hook, sky blue
	10080722	Hose hook, red

Key	Part No.	Description
28	10080723	Hose hook, green
	10080724	Hose hook, light grey
	10080725	Hose hook, yellow
NOT SHOWN:		
	10075150	Lock
	10029509	Nut for lock
	10075158	MSDS Envelope
	10075128	Keys (2) for lock